

# Specification

## Vormatic 49 LCD Display

### Outdoor



## 1 Outdoor advertising machine model

1.1 Choose a 49 inch high brightness LCD screen.

1.2 Brightness requirement is 2000cd/m<sup>2</sup>, with automatic environmental light sensing and tempered explosion-proof glass.

1.4 The entire machine adopts high-quality heat dissipation fans for heat dissipation, and is equipped with lightning protection, overload, overvoltage, overcurrent, and overheating protection equipment. The structure adopts rainproof, dustproof, and sun resistant design.

1.5 Function requirements: Adopting an Android motherboard, supporting WiFi and RJ45 interfaces, supporting simultaneous control of all machines or single control of a single machine, supporting full HD 1920x1080 decoding.

## 2 Features of outdoor advertising machines

**Fashionable appearance:** Standard shell, professional design of elegant and fashionable shells according to customer needs, diverse styles, high-end and extraordinary;

**Timed backlight:** Supports 10 sets of timed backlight control for convenient and easy operation;

**Intelligent temperature control:** The intelligent temperature control system maintains a constant temperature and dry environment inside the body to prevent fogging and condensation;

**Dust and Waterproof:** The entire machine is designed with airtightness to prevent external dust and water from entering the interior, meeting the IP55 standard;

**Sunscreen and Explosion proof:** The outer shell is made of galvanized steel plate, which has been professionally treated with external powder spray paint, waterproof, sunscreen, anti-corrosion, and explosion-proof surface technology by specialized users; Can be used outdoors for up to 10 years without fading;

## 3 Product Function Introduction

### 3.1 Display module

(1) Adopting industrial grade high reliability modular design, it is easy to use, beautiful, easy to maintain, and has complete protective measures.

(2) High resolution, high contrast, high brightness, greatly enhance the sense of image hierarchy, and can better express details.

(3) Equipped with automatic elimination of residual images, UV protection, thermal insulation against sunlight, automatic light sensing, green energy-saving protection for long-term use of LCD screens.

(4) Equipped with black level extension adaptive function, enhancing the deep sense of image scene.

(5) Using an industrial grade LCD screen, the video images are more bright and three-dimensional.

(6) 16.7M color, the picture is more natural, and the delicate picture truly has no trailing edges.

(7) Equipped with intelligent temperature control, environmental protection, and high reliability and stability, it is particularly suitable for working in harsh environments.

(8) Ultra long lifespan, working continuously for 7 \* 24 hours, up to 60000 hours or more.

(9) Using a wide temperature LCD panel, the working temperature can reach a working environment of -40-+85 ° C

## 3.2 Electrical parameters

(1) The outer shell is made of fully galvanized steel plate, and the outer surface is coated with imported metal paint. It is made of anti magnetic, anti-static, and imported waterproof materials. The entire machine is IP55 waterproof, and is designed to be waterproof, dustproof, anti-theft, and explosion-proof all day outdoors.

(2) High reliability electrical protection: leakage, overload, overvoltage protection, lightning protection device, over temperature protection, etc.

(3) Sound system: Adopting a dual channel, stereo surround sound amplifier system, with an output power of 8 ohms 2 x 10W.

(4) The working environment temperature design standard is +85 °~-40 °, and high-quality combination fans are used for cooling.

(5) Protective glass: 8mm tempered explosion-proof glass is used.

(6) The various systems of the entire machine adopt modular design principles, and are designed for sustainability and maintainability.

(7) Machine fixation method: Multiple M18-24 screw columns are poured from the ground, inserted into the bottom of the machine and fixed with nuts.

(8) Light sensing system: The screen backlight adopts automatic ambient light sensing, and the screen brightness is adjusted in real-time to meet the clear image display in strong sunlight environment, while ensuring that the screen is not dazzling and energy waste at night.

## 3.3 Playback Content

(1) Use digital outdoor electronic display screen to play pictures, animations, videos and other rich and colorful mass content, reflecting the progressiveness of community publicity.

(2) Playing lively and vivid video content can increase the fun of promotional content, enhance touch function, interact with the public, attract the public, and form effective communication.

(3) Through an intelligent network system, content can be played synchronously across multiple devices nationwide without leaving home.

## 4 Configuration Checklist

Component part	Parameter Category	Specification, model and description
Sheet metal shell	Sheet metal material	The sheet metal shell is made of 1.5mm SGCC galvanized steel plate.
	Sheet coating	The inner layer is sprayed with zinc rich base powder, and the surface layer is sprayed with Aksu outdoor plastic powder for protection.
	Useful life	Ensure a service life of more than 10 years.
	Protection grade	The overall protection level of the machine reaches IP55; Efficient multi-layer filtration system, isolating harmful dust from entering the interior of the machine.
Explosion-proof glass	Property parameter	8mm tempered glass, when damaged by external forces, fragments will form small, obtuse angle particles resembling honeycombs, which are less likely to cause serious harm to the human body. The impact strength of tempered glass is 3-5 times that of ordinary glass, and the bending strength is 3-5 times that of ordinary glass.
Outdoor dedicated high brightness LCD screen	Brightness	2000nits
	Constrast ratio	Screen resolution high definition 1920 * 1080
	Backlight	LED straight down backlight, visible in sunlight; Automatic photosensitive probe, adjusts screen brightness according to ambient light, saves energy and electricity, reduces light pollution, adopts a wide temperature LCD panel, and can reach a working environment of -40+85 ° C
motherboard	Android	Android motherboard: 3288 motherboard, 2GB memory, 8GB storage, operating system Android 5.1
Eletronic control system	Leakage protection	Leakage protection switch, leakage protection, overvoltage protection.
	Time power supply	A microcomputer timing switch that controls the start and stop of the machine in time intervals.
	Lightning protection level	Lightning arrester, lightning protection level C, to prevent instantaneous induced lightning strikes.
	Power supply brand	Industrial grade power supply, stable and reliable power supply.
Cooling system	Temperature control	The intelligent fan integrates temperature control, ensuring that the display screen does not turn black in outdoor environments of -40+85 degrees, and the entire machine works normally.
	Fan type	Adopting imported axial flow fans, equipped with fan speed control plates, automatic temperature sensing, automatic adjustment of fan speed, energy-saving and energy-saving, extending the service life of the fan.
Work environment	Ambient temperature	-40°C to 85°C
	Ambient humidity	5% to 90%
	Working voltage	220V

## 5 Style specifications

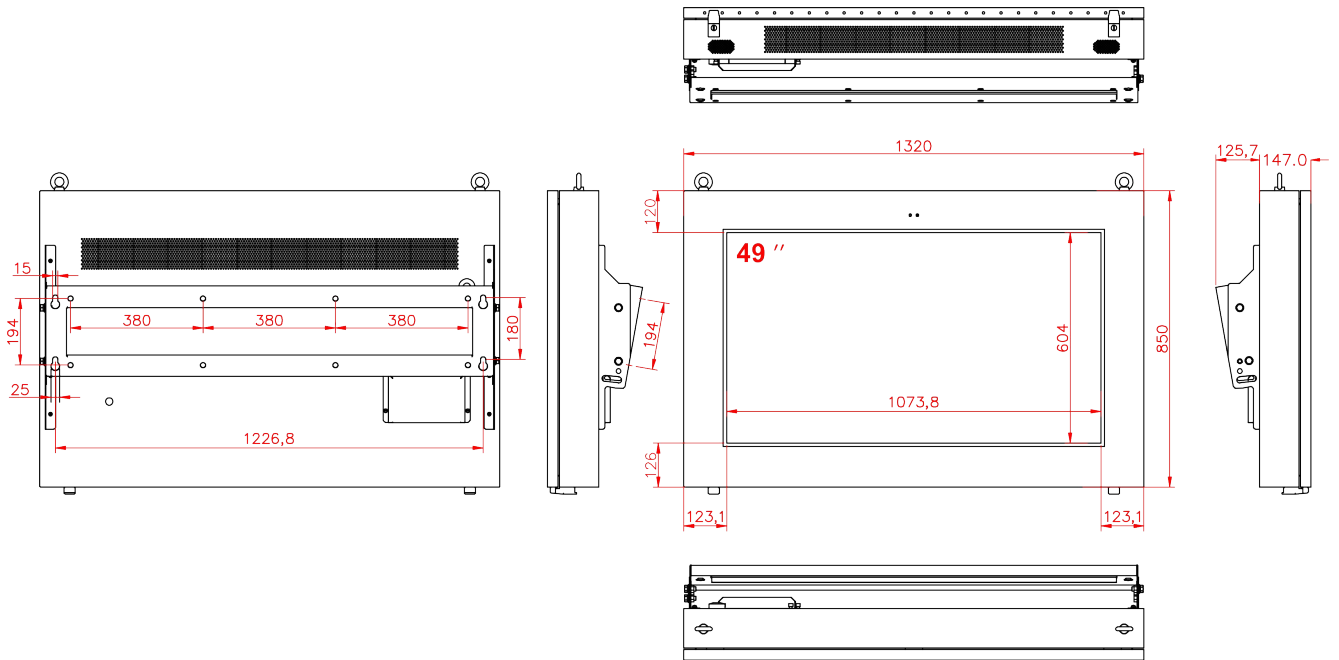

## Parameter:

Component		Parameter
<b>monitor</b>	Size	49inch
	Display area	1074X604mm
	Display ratio	16: 9
	Resolution ratio	1920x1080
	Brightness	2000cd/m <sup>2</sup>
	Contrast ratio	1300: 1
	Viewing angle	178 ° horizontal/178 ° vertical
<b>Android</b>	CPU	RK3288
	RAM	2G DDR
	Storage	8G Flash
	joint	USB2.0*4 RJ45*1
	version	Android 5.1
<b>Drive board</b>	Reserved interface	HDMI、VGA
	Function	Can achieve remote control signal switching
<b>Shell</b>	protection grade	IP55
	Machine weight	78KG
	Installation method	vertical
	Protective glass	6mm Tempered explosion-proof glass
<b>Working parameters</b>	video interface	HDMI
	audio	output
	Brightness control	Automatic photosensitive system
	temperature control	Automatic temperature sensing and stepless speed regulation intelligent fan
	operation temperature	-40°C to +85°C
	Working humidity	5% to 90%
	power supply	220V
	power	280W